



Site Preparation



The following is important information for you & your earthworks contractor to ensure a successful tank installation

3 reasons why your site needs to be prepared properly.

1. Warranty The warranty on an Aquamate tank is subject to the site being prepared as per these instructions. Following these simple yet important instructions will ensure many years of trouble free service from your new tank.

2. Site Costs If a site is not prepared as per these instructions, a fee of \$100 per hour plus the cost of any materials is charged to the customer to modify the site to a standard that ensures a successful tank installation.

3. Call Out Costs If a site is not prepared as per these instructions and can not be modified to a standard that would ensure a successful tank installation, a call out fee is charged to the customer consisting of a days labour for the installation team of \$700, plus travel or accommodation costs. The installation of your tank will then be rescheduled when the site has been prepared correctly.

STEP 1. LEVEL THE TANK SITE

- The site for your new tank must be 2 metres larger than the tank diameter.
- Where ever possible the tank site should be excavated into natural ground rather than built up on fill.
- When excavating a site, adequate drainage must be installed where required to ensure when it rains, water is diverted away from the tank site.
- When using fill to level a site, suitable retaining walls must be installed to maintain the integrity of the tank site.
- The site must be free of sticks, rocks, or other sharp objects. Vegetation or tree roots must be permanently removed from the tank site.

SITE TO BE MADE FLAT AND LEVEL +/- 10mm over the entire tank site

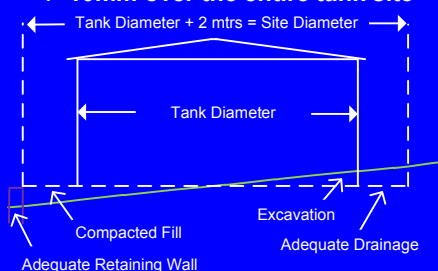

STEP 2. INSTALL THE TANK PAD

- The tank pad must be 2 metres larger in diameter than the tank diameter and 75mm thick.
- The tank pad must consist of Crusher Dust or equivalent material which is less than 6mm in diameter (material greater than 6mm in diameter is not acceptable as it can not be accurately levelled nor does it compact as required).
- The tank pad must be clean & free of any debris or vegetation.
- When the tank pad has been completed, ensure vehicles and live stock do not damage it.

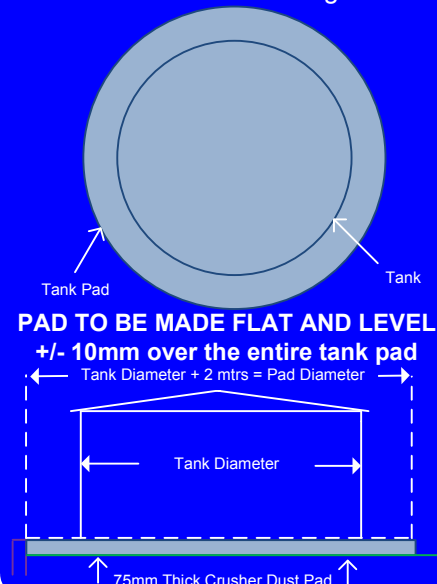

STEP 3. FINAL PREPARATIONS

- When you have completed your tank pad, contact your Aquamate tank supplier. They will then provide you with an installation date.
- A few days prior to installation of your tank, position in a pile in the centre of the tank pad the required cubic meters of clean sand. DO NOT SPREAD THE CLEAN SAND - the installation team will spread the sand during the installation process creating a floor of sand inside the tank. Its sole purpose is to protect the tank liner from being damaged so it must be free of any debris, rocks, vegetation or other sharp objects.
- On the day of installation you will need to organise or have available

A) Enough water to fill 10% of the tank whilst our installation team is on site to ensure the liner is positioned correctly inside the tank.

B) Someone to advise where the fittings need to be located.

C) Payment of balance due.

